

F Curtis, Breech Loader.

No 41489.

Patented Feb 9 1864.

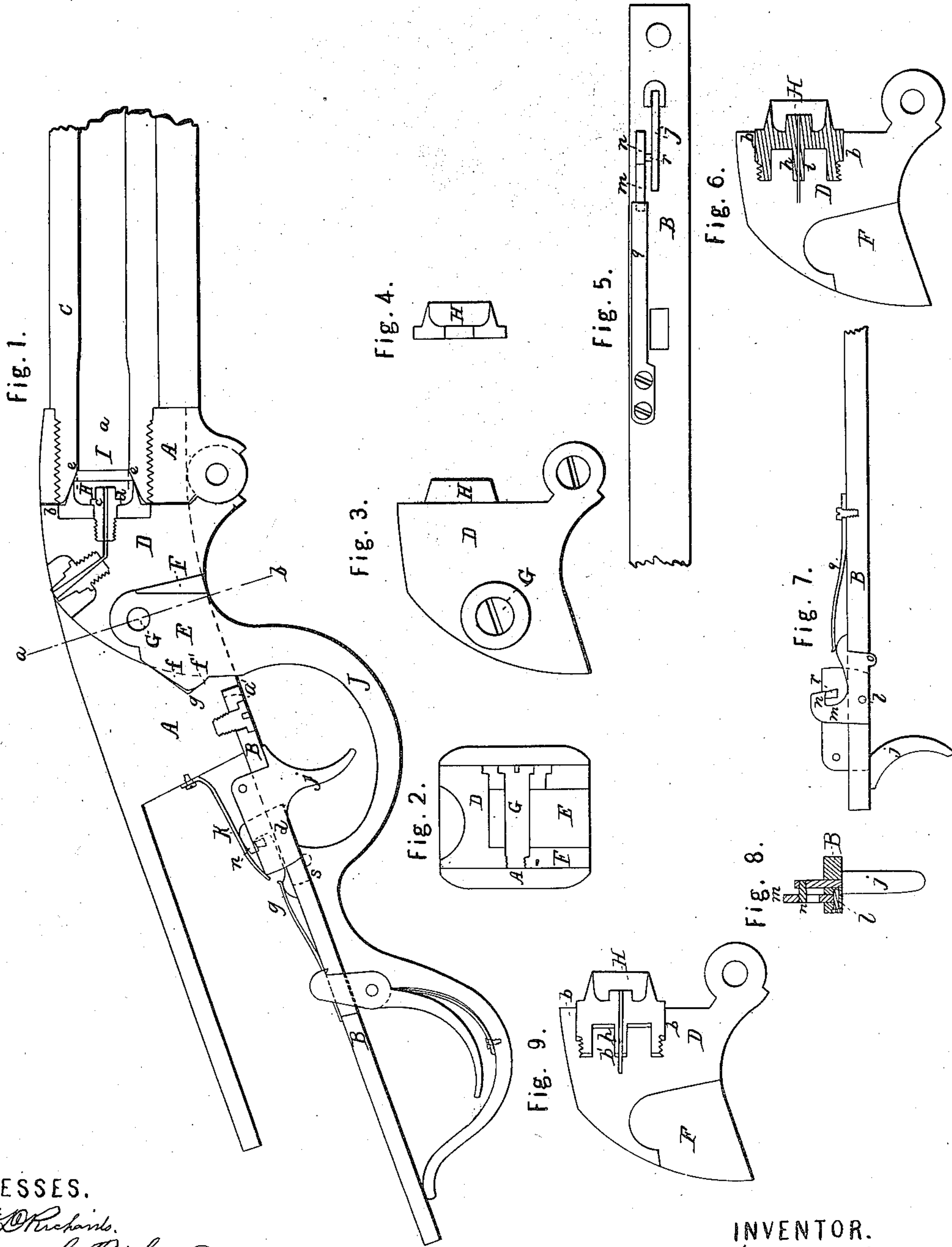

WITNESSES.

W. D. Richards.
Henry C. Richards.

INVENTOR.
Frederick Curtis.

UNITED STATES PATENT OFFICE.

FREDERICK CURTIS, OF NEWTON LOWER FALLS, MASSACHUSETTS.

IMPROVEMENT IN GAS-CHECKS FOR BREECH-LOADING FIRE-ARMS.

Specification forming part of Letters Patent No. **41,489**, dated February 9, 1864; antedated January 29, 1864.

To all whom it may concern:

Be it known that I, FREDERICK CURTIS, of Newton Lower Falls, in the county of Middlesex and State of Massachusetts, have invented a new and useful Improvement in Breech-Loading Fire-Arms; and I hereby declare that the same is fully described and represented in the following specification and the accompanying drawings, of which—

Figure 1 represents part of a fire-arm constructed in accordance with my invention, it being a longitudinal section. Fig. 2 is a vertical and transverse section of the same, taken on the line *ab* of Fig. 1. Fig. 3 is a side view of the movable breech or carrier; and Fig. 4, a section of the expanding cup or gas-check, to be hereinafter described. Fig. 5 is a top view of the trigger-plate removed from the gun. Fig. 6 is a section of a modified form of the breech and gas-check. Fig. 7 is a left-hand view of the trigger-plate; and Fig. 8, a section through the same, showing a "safety-lock," to be hereinafter described.

In a patent granted to James M. Seymour the 20th of May, 1862, and numbered 35,354, he uses a curved tube or "gas-check," and leaves a space between its sides and the sides of the chamber of the barrel. The front end of this gas-check bears against a shoulder formed in the barrel, and Mr. Seymour claims that the explosion of the powder lengthens or expands the gas-check lengthwise against the shoulder of the barrel. In practical experiments, however, it is found that if sufficient space is left between the gas-check and barrel to endeavor to lengthen the check in the manner as described above, it will not stand the strain, and will be split and be broken. In fact, it is utterly impracticable, if not impossible, to lengthen the gas-check by side expansion, as in Mr. Seymour's plan. Another great objection to his plan is the liability of pieces of paper or other substances getting jammed between the end of the gas-check and the shoulder in the barrel, and thus prevent the guard-lever and breech from coming up to place, and also allowing the gun to foul badly. Another objection to Mr. Seymour's plan is the expense and nicety of making and fitting the gas-check and shoulder or groove in the barrel, as the gas-check in this case must bear or fit perfectly at the same time on its front

end and on its outer periphery, which compels the necessity of fitting it by "hand," as it cannot be done by machinery. In a patent granted to me September 17, 1861, and numbered 2,313, and also in an application made by me in January 15, 1862, this expanding cup or gas-check was made so as to fit its whole length with a tight joint, and was also made thin and elastic its whole length, as is also the case in Mr. Seymour's patent. In all these cases the gas-check, under the force of the explosion of the powder, will double or spring sufficiently to throw its front part inward or away from its contact with the barrel and open the joint between them, and allow the gas and dirt to escape and clog the parts, and in time entirely prevent the working of the gun. In my present application I have endeavored to perfect my gun and overcome these objections in the manner as shown by the following description and by the drawings, in which—

A denotes the "receiver" or frame of the arm, and B the trigger-plate.

C is the barrel, and *a* the bore of the same.

D is the movable breech or carrier, and E the holding-guard cam-lever, the same playing within a recess, F, formed in the breech-carrier and connected therewith, and turning on a pin or journal, G, as seen in the drawings.

H is the hollow cup or gas-check, which is attached to the front part of the breech by means of a recess, *b*, made in the breech, into which the base of the gas-check fits, and by a nipple or stud, *c*, which passes through the gas-check and screws into the breech, and which has a shoulder, *d*, bearing against the inner end or bottom of the gas-check, as seen in Fig. 1. The said expanding cup or gas-check in its exterior form is made slightly tapering, as seen in Figs. 1 and 4, while in its interior it is made thin and elastic, or flexible at its front end for a short distance, while its back part is made much thicker or non-elastic, so that only its front end shall spread or expand under the force of the explosion of the powder, which is entirely sufficient to keep a tight joint, while its being thicker at its rear part prevents any "crippling or doubling" of the gas-check or causing its front part to be thrown inward from its contact with the barrel or the inner sides of the chamber thereof. This chamber, which is lettered I in the drawings, is

made of a shorter or more blunt taper, and is longer than the gas-check which enters it, as seen in Fig. 1, so that the explosive gas shall take a direction above the joint at the front end of the gas-check, as shown by the red lines in Fig. 1, thus very much breaking the force of the said gas against the joint. Another object in making the chamber of a shorter taper than the gas-check is that the latter shall not touch the sides of the chamber as it enters and leaves the said chamber until it is entirely up to place, and then only for a short distance from its point, thus preventing friction and wear of the parts and allow the arm to be used with great ease and celerity.

It will be seen that one of the principal advantages or objects in making the gas-check thick at its rear part, as before described, is that it shall be of sufficient strength to withstand the whole force of the explosion of the powder and not split or be broken, thus allowing the rear part of the chamber of the barrel to be made larger than the gas-check in manner and for the purpose as above described.

It has been found in practical tests that the space or part of the tapering chamber of the barrel which extends beyond the front end of the gas-check, and which is marked *e* in Fig. 1, will collect a small quantity of sediment from the explosion of the powder and form a crust or small shoulder directly in front of the gas-check, which helps still further to break the force of the explosion against the joint of the gas-check and barrel. This scale, however, does not adhere to the barrel so hard but that it will be knocked off and removed by a piece of paper or any foreign substance getting between it and the end of the gas-check.

E is the holding-cam lever, which is connected to the breech, as before described, and is furnished at its rear part with a cam-projection, *f*, which, when the breech is in place against the barrel, shuts or slides over a projection, *g*, made in the receiver of the gun. The bearing-face *f'* of the projection *f* is made in the form of a cam, as seen in Fig. 1, so that when the guard is brought up to place by force applied to its handle *J* the action of the said cam on the projection *g* will force the gas-check very tightly up to its place within the chamber of the barrel.

The gas-check, instead of being attached to the breech in the manner as hereinbefore described, may have a screw or "thread" cut upon its base, which may screw into a corresponding female screw made in the breech, as seen in Fig. 6 of the drawings. By this means, if there should be any wear to the gas-check or barrel, by simply turning the gas-check partly round it will be forced forward.

In order that there may not be much space left at the back of the gas-check and around the "touch-hole" as the gas-check is advanced, I form the base of the gas-check with a stud or projection, *h*, which enters a hole or passage, *i*, made in the breech to receive it, the said

projection being but little larger than the touch-hole and fitting tightly in the passage *i*, as seen in Fig. 6. Should the gas-check at any time be forced forward, all the space that would be formed around the touch-hole at its base would be of the size of the hole or passage *i*, as seen in Fig. 9 at *b'*, which is a section of the breech and gas-check, showing the check screwed forward a short distance. This space would not be sufficient to interfere in the least degree with the certain firing of the powder.

B is the trigger-plate, which is attached to the receiver *A*, as seen in Fig. 1 at *a'*. *j* is the trigger, which is connected to the trigger-plate in the usual manner, the spring shown at *k* in the drawings being supposed to represent the pressure of the "sear" of the lock upon the trigger. There is, furthermore, attached to the trigger-plate in much the same manner as the trigger, and turning on a pin or fulcrum, *l*, passing through it and the trigger-plate, a small plate or holding-arm, *m*, which at its upper part is formed with a short projection or hook, *n*, as seen in Fig. 7. The arm *m* also has a small stud, *o*, which extends below the trigger-plate when the breech and guard-lever are down away from the barrel and stock in the act of loading the piece. A spring, *q*, is secured to the trigger-plate, and presses on the rear upper part of the holding-arm *m*. The said holding-arm constitutes a "safety-lock" for preventing the arm from being accidentally discharged, and operates in the following manner: We will suppose the breech and guard-lever entirely up to place, as in Fig. 1 of the drawings. When the guard-lever is drawn down away from the stock or trigger-plate, it allows the spring *q* to partly turn the holding-arm *m* on its fulcrum, or sufficient to force its hook *n* over a stud or pin, *r*, attached to the side of the trigger, as seen in Fig. 7, by this means preventing the trigger from being pulled backward, and throwing down the hammer. As the guard-lever is brought up to place after loading, its part *s* presses against the stud *o*, and turns the arm *m* on its fulcrum, and removes its hook *n* from over the stud *r* of the trigger, and allows the latter to be "pulled" and cause the hammer to fall.

It will be seen by referring to the drawings that the front end of the gas-check is made with a sharp or "knife" edge, which very much aids in preventing the gas and dirt from the explosion from getting into the joint between the gas-check and barrel.

I do not herein claim a "gas-check" intended to be so made that it shall, by expansion, be lengthened and forced against a shoulder in the bore of the barrel, as described in United States Patent numbered 35,354, and granted May 20, 1862; nor do I claim a gas-check or elastic cup made of a soft metal, and bearing its whole length within the barrel, as described in United States Patent numbered 2,313, and granted September 17, 1861, as my present invention is intended to obviate the objections to which these are subject.

I claim—

The combination or arrangement of the gas-check with the barrel, as above described, with said gas-check bearing within the chamber of the barrel on its outer periphery only at its front end, and with the chamber of the barrel made of the form and extending beyond the gas-check, essentially in manner and for the purposes as above described.

In testimony whereof I have hereunto set my signature this 21st day of March, A. D. 1863.

FREDERICK CURTIS.

Witnesses:

W. D. RICHARDS,
HENRY C. RICHARDS.